

ANNALES ACADEMIÆ SCIENTIARUM FENNICÆ

SERIES A

II. CHEMICA

253

TRANSITION PATH SELECTION BETWEEN
AMMONIUM NITRATE SOLID PHASES IV, III AND II

MAUNO E. E. HARJU

University of Jyväskylä
Department of Chemistry
FIN-40351 Jyväskylä
Finland



HELSINKI 1994
SUOMALAINEN TIEDEKATEMIA

Editor: JOUKO KOSKIKALLIO
Physical Chemistry Laboratory
Department of Chemistry
P.O. Box 13 (Meritullinkatu 1 C)
FIN-00014 University of Helsinki
Finland

ANNALES ACADEMIÆ SCIENTIARUM FENNICÆ

SERIES A

II. CHEMICA

253

TRANSITION PATH SELECTION BETWEEN
AMMONIUM NITRATE SOLID PHASES IV, III AND II

MAUNO E. E. HARJU

University of Jyväskylä
Department of Chemistry
FIN-40351 Jyväskylä
Finland

HELSINKI 1994
SUOMALAINEN TIEDEAKATEMIA

Copyright ©1994 by
Academia Scientiarum Fennica
ISSN 0066-1961
ISBN 951-41-0737-3

Received 12 January 1994

YLIOPISTOPAINO
HELSINKI 1994

PREFACE

This work was carried out in the Department of Chemistry of the University of Jyväskylä, Finland, during the years 1989 - 1993, and at the School of Chemical Sciences, University of East Anglia, Norwich, The United Kingdom, during seven months in 1990 - 1991.

I wish to express my deepest gratitude to Professor Jussi Valkonen, University of Jyväskylä, for his invaluable advice and continuous and enthusiastic interest in my work.

I owe my gratitude to the steering group of the project to which this work in part belonged. Besides Professor Valkonen, the group consisted of Timo Mattila, Pekka Suppanen, Robert Perander, and Juhani Poukari, all from Kemira Oy, Markus Koskenlinna and Juha Björkroth both from the Technology Development Centre. Heikki Hero and Harri Kiiski of Kemira Oy worked in close cooperation with the investigation and are deserving of special thanks.

The guidance in chemometrics given by Professor Pentti Minkkinen, Lappeenranta University of Technology, and Veli-Matti Taavitsainen, Kemira Oy, was much appreciated and is gratefully acknowledged.

The co-operation of the scientists of University of East Anglia leaves me in a debt of deep gratitude. For special thanks, I would single out Professor Andrew Thomson, Professor John Davies, Professor Sidney Kettle, Dr. Upali Jayasooriya and Dr. Daniel Wolverson.

My co-workers Eija Kestilä, Jari Lehto, Leena Tomperi, Elina Hänninen, Satu Pitkänen, and all those undergraduate students that I had the pleasure to work among, created an inspiring atmosphere. I wish to thank them all, along with the rest of the staff of the Department.

Yet further thanks are extended to those people from the universities of Joensuu, Turku, Oulu and Helsinki and from industry in Belgium, Great-Britain, Denmark, the Netherlands, Czechoslovakia and Finland who placed their expertise at my disposal.

I am grateful to Dr. Kathleen Ahonen for revising the language.

For my wife Heljä and sons Miikka and Niko, I reserve my warmest thanks, for their unfailing support and patience.

The financial support of Kemira Oy, the Technology Development Centre, the Finnish Academy, the Royal Society of Chemistry and the Ellen and Artturi Nyssönen Foundation is gratefully acknowledged

Jyväskylä, October 1993

Mauno Harju

I dedicate this work to my Family.

ABSTRACT

Study was made of factors affecting the transition paths between ammonium nitrate solid state phases IV, III and II. The effect of the sample preparation method was investigated by differential scanning calorimetry (DSC), transition mechanisms were explored with simultaneous DSC and Raman spectrometry developed for *in situ* investigation of the transitions, and the relationship between phase IV structure and the transition paths was studied by X-ray powder diffraction (XRD) and DSC. The results were analysed by partial least-squares regression (PLS) and principal component analysis (PCA).

Three categories of transitions were observed: a) the principal transitions $IV \rightleftharpoons III \rightleftharpoons II$ and $IV \rightleftharpoons II$, b) the parallel transitions $IV \rightarrow III \rightarrow II$ and $IV \rightarrow II$ on heating or $II \rightarrow III \rightarrow IV$ and $II \rightarrow IV$ on cooling and c) the forward-and-back transitions $IV \rightarrow II$ ($\rightarrow III \rightarrow II$) on heating and $II \rightarrow IV$ ($\rightarrow III \rightarrow IV$) on cooling. The phase transition paths were shown to be influenced by the sample preparation method, which evidently affects the degree of disorder of phase IV.

The existence of an intermediate phase II^* between phases IV and III was confirmed. The life-time of II^* was seven minutes maximum and decreased with decreasing transition temperature.

The multivariate analysis of XRD and DSC data showed that a relationship exists between the XRD patterns and the transition paths and confirmed that PLS could be used to predict the transition path that the sample would undergo on heating. PCA indicated seven per cent of the variation in the XRD patterns to be related to the structural factors connected with the phase transition path selection.

CONTENTS

PREFACE

ABSTRACT

CONTENTS

1. INTRODUCTION	9
2. STRUCTURAL STUDIES ON AMMONIUM NITRATE	11
2.1 Methods employed in the structural investigations	11
2.2 Crystal structures of ammonium nitrate	12
3. SOLID PHASE TRANSITIONS BETWEEN AMMONIUM NITRATE PHASES IV, III AND II	15
3.1 Evaluation of experimental methods	16
3.1.1 Differential scanning calorimetry	16
3.1.2 Combined differential scanning calorimetry and Raman spectrometry	17
3.1.3 X-ray powder diffractometry	19
3.1.4 Sample preparation	20
3.2 Observed phase transition paths between the ammonium nitrate solid phases IV, III and II	21
3.3 Transition temperatures and energies	22
3.4 Effect of the sample preparation method	24
3.5 Mechanisms of the phase transitions between ammonium nitrate phases IV, III and II	25
3.6 Statistical evaluation of the effect of disorder on the transition paths between ammonium nitrate phases IV, III and II	29
4. CONCLUSIONS	32
5. REFERENCES	34

1. INTRODUCTION

Ammonium nitrate, NH_4NO_3 , was first synthesised by J. R. Glauber¹ from ammonium carbonate and nitric acid in 1659. Industrial production was started by BASF in 1913. Today the ammonium nitrate process utilizes ammonia produced by the Haber-Bosch process and nitric acid obtained by the Ostwald process. The raw materials for the production are air and water. The main uses of ammonium nitrate are as a nutritive agent in fertilizers and as an oxidizer in explosives.^{1,2}

If the ammonium nitrate granules used in fertilizers are heated and cooled several times, they may crack. This decreases the bulk density, breaks down the granules and increases the porosity. All these factors lower the quality of the fertilizer. The high porosity also constitutes a safety risk, as decomposition by thermal reactions and explosions in the presence of organic compounds are then more likely. For this reason the amounts of heavy metals which can catalyse decomposition reactions, the amounts of organic compounds which may trigger explosions and the total amount of ammonium nitrate in fertilizers are regulated by law.^{2,3}

Solid ammonium nitrate has eight phases with differing crystal structures.⁴⁻¹¹ On heating and cooling between 270 and 370 K, solid-to-solid phase transitions occur¹¹ between phases IV, III and II. Basically, two alternative phase transition paths are possible: $\text{IV} \rightleftharpoons \text{III} \rightleftharpoons \text{II}$ and $\text{IV} \rightleftharpoons \text{II}$. The transitions are difficult to reproduce and particularly the transitions $\text{IV} \rightleftharpoons \text{III}$ are responsible for the degradation of fertilizer granules.^{2,11-13}

Two explanations of the poor reproducibility have been proposed. It has been argued that samples containing water would always undergo transitions to phase III, while the transitions $\text{IV} \rightleftharpoons \text{II}$ would take place only in very dry samples.¹⁴⁻¹⁷ There are contradictory reports as well, however.¹⁸ The other proposed explanation is the thermal history of the samples: it has been proposed that the samples would undergo different transitions according to their thermal history.^{11,19}

This work deals with the notoriously poor reproducibility of the phase transitions $\text{IV} \rightleftharpoons \text{III} \rightleftharpoons \text{II}$ and $\text{IV} \rightleftharpoons \text{II}$ in experimental work and with the factors affecting the transition paths. Ultimately, the goal was a better understanding of

the effect of these transitions on the physical and quality properties of ammonium nitrate fertilizer. New approaches offered by recent developments in laboratory techniques and data analysis methods were applied. The paths were studied by differential scanning calorimetry (DSC) and details of the transition mechanisms were examined with a novel combination of DSC and Raman spectrometry developed for simultaneous measurements allowing *in situ* investigation of solid state transitions.^{I-IV} These studies showed that sample preparation method can affect the degree of disorder of ammonium nitrate phase IV and that the disorder plays a significant role in the transition path selection. The disorder of ammonium nitrate phase IV was evaluated and the transition paths were predicted from X-ray powder diffraction (XRD) data by methods of partial least squares regression (PLS) and principal component analysis (PCA).^V

Chapter 2 summarizes the methods reported in the literature for determining the crystal structure of ammonium nitrate and describes the structures in a general way. Chapter 3 reports the experiments on ammonium nitrate solid phase transition paths undertaken in the present investigation and discusses the results in the context of the literature. Conclusions and some proposals for further work are recorded in Chapter 4.

2. STRUCTURAL STUDIES ON AMMONIUM NITRATE

This chapter surveys the large number of studies on the crystal structure of ammonium nitrate. Because of the dynamic nature of some of the ammonium nitrate phases, discussion is not limited to the crystallographic crystal structure determinations. First the methods of investigation are reviewed, and then the presently accepted structures are described with the detail needed to understand the problems of the present work.

2.1 Methods employed in the structural investigations

X-ray powder and single crystal X-ray diffraction were the first diffraction methods applied in investigation of the structure of solid ammonium nitrate. All but one of the space groups resolved with X-rays were correct, and the X-ray studies are still usually quoted^{7,11,14} for the phase I. The ammonium protons proved a stumbling block for the X-ray investigations, however, and for the other phases the X-ray studies have now yielded to neutron diffraction results.⁴⁻⁷ Neutron diffraction reveals the protons so much better that the wrong space group was shown to have been assigned to phase V in the X-ray studies.^{7,20-22}

Vibrational spectroscopy methods - infrared,²³⁻²⁵ Raman²⁶⁻³⁷ and inelastic incoherent neutron³⁸ spectroscopy - have thrown light on the rotations and heteroionic coupling of the two sets of ions. Electrical conductance measurements have shown that the ionic movements occur on a different level in the different phases,^{14,39-41} and NMR has revealed much about the dynamics of the ions.⁴²⁻⁴⁷ Magnetic susceptibility measurements have show that the magnetic anisotropy varies with the phase, further revealing the dynamics of the ions.⁴⁸ Optical microscopy was one of the earliest methods to reveal the existence of the phase transitions and allowed the transition mechanisms to be proposed.^{14,49-51}

2.2 Crystal structures of ammonium nitrate

Ammonium nitrate has eight crystal phases stable at different temperatures and pressures.^{4,11} Crystal structures of phases I to V are known and are stable at both normal and higher pressure.^{4,7,11} Structures of the high pressure phases VI and VIII and the normal pressure phase VII are not known and the existence of phase VII has been disputed.^{7-9,21,22,52} Phase VIII has been reported only once and has not been confirmed.¹⁰

Table 2.1 summarizes the crystal structures of ammonium nitrate. The structures of phases IV and V have been determined in single crystal neutron diffraction and phases II and III in powder neutron diffraction experiments.^{4,7} The structure of phase I has been determined by X-ray diffraction and confirmed by neutron diffraction studies.^{11,53} As explained below, the ordering column in the table refers to the dynamics of the phases.

Pure protonic ammonium nitrate was used for the structure resolution of phases I, II, and IV and the fully deuterated compound for phases V and III. The phase III structure resolved from the pure ammonium nitrate samples was confirmed by single crystal neutron diffraction experiments^{6,54} where ammonium nitrate was doped with 5% KNO_3 . At 5% concentration, KNO_3 causes ammonium nitrate to crystallize in phase III at room temperature.⁵⁵

Characteristically the structures of the phases differ in the dynamic disorder of the ions, which originates in ionic rotations and reorientations.^{4,7,11,14} In the higher temperature phases I, II and III the movements of the ions are significant and no simple set of structure coordinates can describe the positions of the atoms.^{4,5,11}

Hendricks, Posnjak and Kracek¹¹ suggested back in 1932 that in phase I both sets of ions rotate with a constant angular velocity in the three orthogonal planes. These early experiments were carried out with X-ray diffraction. The proton positions of the ammonium ions could not be determined and the positions of the oxygen atom could not be fixed. Later Shinnaka⁵⁶ and Yamamoto and Shinnaka⁵⁷ suggested that there were 3, 6, 8 or 12 equivalent orientations for the nitrate ions to rotate among. Ahtee *et al.*,⁵³ in their neutron experiment, presented evidence supporting a model of nearly freely rotating ions.

The fact that lattice vibrations were not seen in Raman measurements of phase I is further evidence for the rotation of the ions.³⁵ Moreover, the magnetic anisotropy drops to zero in the phase transition II \rightarrow I, and since the anisotropy in ammonium nitrate is due to the planar nitrate ions, the drop also supports the

rotation of the nitrate ions.⁴⁸ Likewise, NMR measurements support the model of freely rotating ions.^{43,44}

Ammonium nitrate phase I is plastic in physical appearance and can be moulded to some degree.⁴² The other phases are brittle and the crystals break if handled too roughly, as was verified during the present investigation. The plasticity of phase I is caused by the ionic rotations. Whatever the manner of rotation of the ions in phase I, it is clear that there are no fixed orientations for the ions and that they move more or less freely in their positions.^{11,14,53,56-58}

Table 2.1. An overview of the structure data of ammonium nitrate solid phases.

Phase	Unit cell	Space group	Ordering		Reference
			NH ₄ ⁺	NO ₃	
Temperature range		Crystal system			
I 398 - 442 K	$a = 4.3655 \text{ \AA}$ $Z = 1$	<i>Pm3m</i> Cubic	Rotating	Rotating	11
II 357 - 398 K	$a = 5.7193 \text{ \AA}$ $c = 4.9326 \text{ \AA}$ $Z = 2$	<i>P42₁m</i> Tetragonal	Disordered	Disordered	4
III 305 - 357 K	$a = 7.7184 \text{ \AA}$ $b = 8.8447 \text{ \AA}$ $c = 7.1642 \text{ \AA}$ $Z = 4$	<i>Pnma</i> Orthorhombic	Disordered	Ordered	5
IV 255 - 305 K	$a = 5.7574 \text{ \AA}$ $b = 5.4394 \text{ \AA}$ $c = 4.9298 \text{ \AA}$ $Z = 2$	<i>Pmmn</i> Orthorhombic	Ordered	Ordered	6
V ? - 255 K	$a = 7.98 \text{ \AA}$ $b = 8.0027 \text{ \AA}$ $c = 9.8099 \text{ \AA}$ $Z = 8$	<i>Pccn</i> Orthorhombic	Ordered	Ordered	7
VI	Unknown				
VII	Unknown				
VIII	Unknown				

In phase II the ions do not rotate.⁴ Neutron diffraction studies^{4,59,60} have shown that the nitrate ions reorientate in their own planes between two extreme orientations separated by 60° and that the ammonium ions move between two alternative orientations separated by 90° . Raman measurements^{35,36,61,62} indicate that the H...O bonds between the ions prevent such large movements as in phase I. The magnetic anisotropy⁴⁸ is greater than in phase I. Likewise, as NMR studies⁴³ have shown, the nitrate ions are more highly orientated in phase II than in phase I.

Phase III differs from all the other structures in the positions of the central nitrogen atoms relative to each other, these being less regular.^{11,14} The amplitude of the reorientations of the nitrate ions⁵⁴ is negligible compared to phase II, but the ammonium ions reorientate between two alternative orientations separated by 42° . Raman, NMR and magnetic susceptibility measurements also support the disordered structure.^{35,36,48,61,62}

In phase IV each nitrate ion is bonded from one of the oxygens to a hydrogen of two ammonium ions.⁶ Through the bonding of another hydrogen of the ammonium ions to an oxygen of a nitrate ion a chain of ions is formed. The chains are then connected by weak hydrogen bonds into a sheet. There is no reorientation of the ions in phase IV. The thermal motion of the ammonium ions continues to be large, but the interactions are sufficient to prevent the rotation of the nitrate ions.⁶

In phase V one half of the nitrate ions are turned orthogonally to the other half.^{7,22} No reorientations take place.^{7,22} When Amoros *et al.*²⁰ first determined the structure with X-rays, they wrongly defined the space group as $P4_2$. This has caused confusion,²⁸ but is now corrected by Ahtee *et al.*⁷ and Choi and Prask.²²

3. SOLID PHASE TRANSITIONS BETWEEN AMMONIUM NITRATE PHASES IV, III AND II

On heating, ammonium nitrate may undergo transitions¹¹ $IV \rightarrow III \rightarrow II$ or it may bypass phase III and undergo transition $IV \rightarrow II$. The literature offers no straightforward explanation for the path selection, but the most frequently mentioned factors are the water content and thermal history of the sample.^{11,14,19} It has been argued that samples with more than 0.1% water would always undergo transitions to phase III, while the transitions $IV \rightleftharpoons II$ would take place only in very dry samples.¹⁵ There are contradictory reports as well, however.¹⁸

The thermal history refers to the temperature profile that a sample has acquired since crystallization. Hendricks, Posnjak and Kracek¹¹ have suggested that ammonium nitrate has a thermal memory - a mechanism for remembering the thermal history. In connection with this they have proposed the existence of phases IV' and II' distinct from the phases IV and II. Whereas phases IV' and II' undergo transitions $IV' \rightleftharpoons III \rightleftharpoons II'$, phases IV and II undergo transitions $IV \rightleftharpoons II$. The attempts of this group to determine the structures of phases IV' and II' did not prove successful.¹¹

The present investigation demonstrates that the concentration of water is not critical for the phase transition path selection; more important is how the water concentration of the samples changes.¹ It also shows that there is a clear connection between the thermal history of the samples and the transition paths.¹ However, instead of the distinct phases IV and IV', ammonium nitrate phase IV can exist as a continuous series of structures differing from each other in the degree of order, which is the dominant reason for the different transition paths.¹

3.1 Evaluation of experimental methods

The transitions between ammonium nitrate phases IV, III and II were investigated by differential scanning calorimetry, combined differential scanning calorimetry and Raman spectrometry, and X-ray powder diffractometry.^{1,v} Samples for the investigation were prepared in several different ways.^{1,v}

3.1.1 Differential scanning calorimetry

Differential scanning calorimetry (DSC) gave information on the phase transition onset temperatures, changes of enthalpy and changes of heat capacity.¹ The rapidity of DSC allowed the generation of a large number of measurements and made it easy to replicate these using either the same sample, i.e. by doing temperature cycling, or separate samples. The sample size was 1 - 10 mg. Larger samples gave rise to inaccuracies in the temperature and enthalpy change determinations.⁶³ The small sample size had the disadvantage that it was difficult to compare the DSC results with those of other methods or to handle real world problems where larger amounts of ammonium nitrate are involved.

The most serious disadvantage of DSC was that the amount and the changes in the amount of water could not be controlled during the measurements. Moreover, the samples were too small to allow Karl-Fischer titrations to check the concentration after measurements. Determinations of the concentration from the melting point in DSC gave contradictory results from those obtained by Karl-Fischer titration. The problem in determining the water content from the melting point was that the melting tended to occur simultaneously with the phase transition II → I, at about 400 K, even though it should have occurred at higher temperature. Thus, the only reliable measure of the water concentration of the DSC samples was the concentration obtained by Karl-Fischer titration before the DSC measurements.

The transitions between phases IV, III and II could be identified reliably¹ by observing the transition temperatures, changes of enthalpy, changes of heat capacity and all transition peaks in the DSC curves between 283 and 373 K. Great care was necessary in the interpretation, however, as there was a danger of confusing the transitions IV → III and IV → II on heating, and after transitions IV → III → II on heating, of interpreting transition II → IV as transition III → IV on cooling. In the latter case, the transition temperature of II → IV may be several degrees below IV → III, so that the two peaks look like the transitions IV ≠ III.

Yet one further misinterpretation could easily take place: if the transition III \rightarrow IV did not occur at all because of insufficient cooling, the transition II \rightarrow III could be mistaken for II \rightarrow IV. The DSC equipment was easily cooled below the temperature of transition III \rightarrow IV, which helped in interpreting the curves.

3.1.2 Combined differential scanning calorimetry and Raman spectrometry

Complex transition peaks appeared in the DSC curves at 318 to 333 K on heating and at 328 to 303 K on cooling.¹ The transition mechanisms of these transitions were deduced from the onset temperatures T_o , changes of enthalpy ΔH and changes of heat capacity Δc_p in the transitions.¹ To understand the DSC curves better, combined DSC and Raman equipment was constructed to monitor the energy transfer simultaneously with the structure.^{ii,iii,iv}

During the parallel XRD and DSC measurements, it became evident that the phase transition paths between phases IV, III and II might not be the same in different equipment, and a method providing *in situ* information on transition energies and the structure of the samples would be desirable. The only techniques used in combination with DSC in the literature were XRD and Fourier transform infrared spectroscopy (FTIR).^{64,65} In the case of XRD, the sample size and the comparatively long measuring times required for the available equipment made it unsuitable for simultaneous investigations. In FTIR-DSC the transmittance is measured, and KBr windows are therefore used.⁶⁵ Unfortunately, not only may ion exchange occur between KBr and ammonium nitrate,⁶⁵ but the sample dilution methods of FTIR are not suitable for ammonium nitrate.

By 1990, however, when the simultaneous method was sought, FT Raman spectrometry had developed into a routine, commercially available method. The introduction of charge coupled device (CCD) detectors had also made the dispersive Raman spectroscopy easier. In both FT and CCD Raman methods the spectra were faster to collect than by conventional scanning dispersive spectrometry. Basically, one spectrum can be acquired in just seconds. Sample dilution is not required and the sample size is much smaller than in DSC.

The combined DSC-Raman equipments were built by removing the DSC oven assembly from its original place and putting it into the sample compartment of the Raman spectrometers.^{ii,iii} 180° collection geometry was used in both spectrometers.^{ii,iii} Figure 3.1 illustrates the arrangement in the FT Raman

spectrometer. A cooling device for the DSC was constructed at a later stage to allow investigations below room temperature.^{IV,66}

The alignment of the invisible near infrared laser beam in the FT spectrometer required special attention. For the rough alignment, the sample oven was first covered with a paper that had been coloured black with a graphite pencil. The beam burned small holes into the paper and with the help of the holes the sample was moved into the beam. The paper allowed the sample compartment lid to be closed during the exposure, which was not possible with the commercial NIR to VIS converters generally used for visual detection of NIR radiation. The paper also was easier to use than the IR TV cameras often employed for the purpose. When the beam hit the sample, an x-y-z fine adjustment was done with the help of the interferogram peak search facility to find the position for maximum scattering. The computer could not do the Fourier

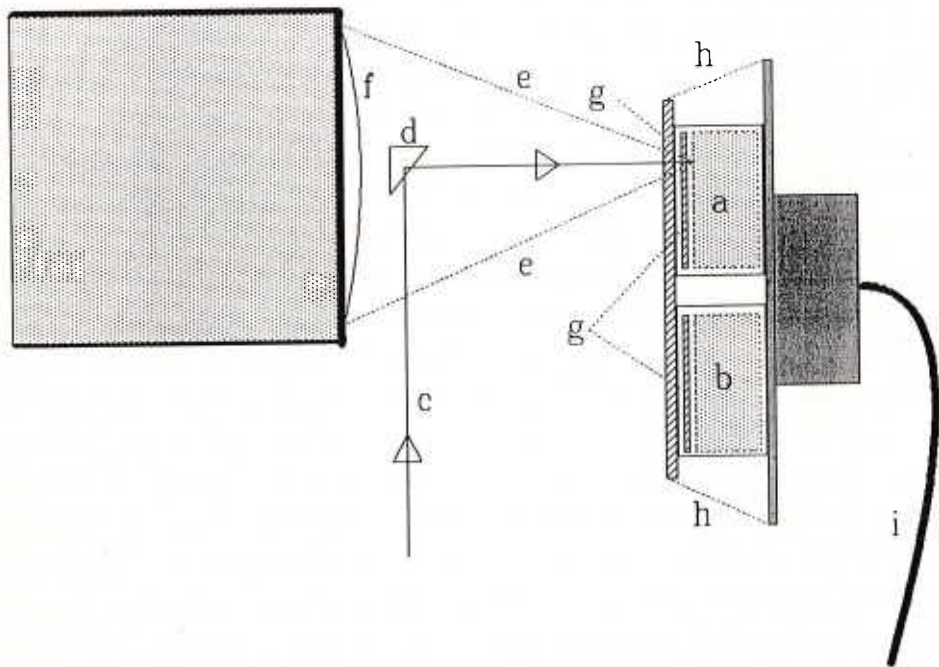

Fig. 3.1. The arrangement of the DSC oven assembly in the FT Raman spectrometer seen from the side. a) sample oven, b) reference oven, c) laser beam, d) prism, e) scattered radiation, f) collecting lens of the spectrometer, g) glass covers, h) springs holding the covers and i) cable to the DSC equipment.

transform in real time and the interferogram was therefore used instead of a peak. For the same reason, the FT spectra could not be followed during the temperature scanning collections; the time scale was badly disturbed if the transform was made simultaneously with the collection. Sample adjustment was easier in the CCD Raman spectrometer than in the FT Raman spectrometer, as the beam was visible and the work, viewed through safety glasses, could be done with low laser power. It also was possible to see the actual spectrum immediately after it had been collected.

In the CCD Raman equipment the sample compartment was partially open and the laboratory air fluctuations totally disturbed the DSC measurements. This problem was overcome by installing an open cylinder to protect the ovens so that the laser beam could be directed into the sample and the scattered radiation could be collected. In the FT Raman spectrometer the sample compartment was closed and there was no air fluctuation to interfere with the DSC measurements.

The CCD Raman proved to be more suitable than the FT Raman because of the fast spectral collection and easily accessed lattice vibrations.^{iii,iv} The spectral range of the CCD Raman was limited to about 1000 cm^{-1} at one go if no compromise with the resolution was sought.ⁱⁱⁱ This limitation could have been overcome by using spectral windows that make it possible to measure successive spectra in different ranges, but longer collection times would then have been required. FT Raman had a wide spectral range, but the lattice region below about 80 cm^{-1} was not accessed.^{ii,iii} Unfortunately, working time on the CCD Raman equipment was limited and, in the end, fewer measurements were made than with the FT Raman.

3.1.3 X-ray powder diffractometry

X-ray powder diffractometry (XRD) measurements at room temperature were made to compare the degree of order of the ammonium nitrate phase IV crystals with the transition paths on heating in DSC.^v The data were analysed by means of partial least-squares regression (PLS) and principal component analysis (PCA).^v Some experimental factors were especially taken into account: samples were sieved to equal grain size to minimize packing problems, water content was allowed to stabilize in the same atmosphere as where the XRD measurements were carried out, and the heating effect of the X-rays was reduced by exposing all samples to the X-ray the same length of time. The transition paths were

investigated in DSC before and after the XRD measurements, to note any changes in the phase transitions taking place during the XRD measurements.^v

Diffuse scattering X-ray diffraction of single crystals has been used to study the disorder of phase I and phase II ammonium nitrate single crystals.^{57-59,67} Single crystal studies were not possible in our case, however, because the single crystals do not tend to undergo transitions to phase III, and if they do undergo such transitions, the crystals crack.^{35,68,69}

XRD was also used to identify the phase of the ammonium nitrate samples at different temperatures. The patterns were compared with the literature data.⁷⁰ Parallel XRD and DSC measurements showed that samples, even though of similar origin, could undergo different transitions in the two instruments. This meant that the sample temperature is no guarantee of the phase of the sample and that isothermal methods cannot give reliable information about the path without monitoring of the transitions during heating or cooling by another method. Compared with DSC, XRD revealed fewer details of the transition taking place during heating or cooling. Nor was XRD suitable for temperature cycling since the samples could not be cooled below room temperature in the XRD equipment, and the transition III → IV did not take place in a reasonable time. Owing to the thermal expansion, the results were also affected by dramatic changes in the sample packing in the sample holder.

3.1.4 Sample preparation

The ammonium nitrate samples were recrystallized from deionized water because their thermal history had to be known.^{1-v}

Sometimes a sample that first underwent transition IV → II could after one or more heating and cooling cycles undergo the transitions IV → III → II. When the investigations began the only way to make a certain transition occur was to repeat the experiments as many times as needed. The effect of the sample preparation method first became evident when a correlation was noticed between the age of the samples and the phase transition paths IV → III → II and IV → II of the trial-and-error experiments. The samples that had been untouched for longer times more often underwent transition IV → II. Since the age of the sample could be presumed to affect the order of the crystals and thereby the transition paths, the sample preparation method was varied with a view to the ordering of the crystals: namely the ammonium nitrate melt was cooled at different rates.¹ The desired result was achieved and the samples undergoing specific transitions could

from thereon be produced with a high probability.¹ The effect of ageing of the samples also was systematically tested at different temperatures.¹

The water concentration was shown not to correlate with the transition path, but as water clearly had something to do with the paths, drying experiments were combined with the heating tests.¹ Moist samples undergoing transitions IV \rightarrow II were dried at different temperatures and the path was compared with reference samples that had the same thermal history but were not dried.¹

3.2 Observed phase transition paths between the ammonium nitrate solid phases IV, III and II

The phase transition paths between solid state phases IV, III and II of ammonium nitrate observed in the present work fell into three categories: a) the principal transitions IV \rightleftharpoons III \rightleftharpoons II and IV \rightleftharpoons II, b) the parallel transitions, where the samples may undergo transitions IV \rightarrow III \rightarrow II and IV \rightarrow II on heating or II \rightarrow III \rightarrow IV and II \rightarrow IV on cooling and c) the forward-and-back transitions IV \rightarrow II (\rightarrow III \rightarrow II) on heating and II \rightarrow IV (\rightarrow III \rightarrow IV) on cooling.¹

The category a) paths are frequently reported in the thermal analysis literature.⁷¹⁻⁷⁸ The double arrows ' \rightleftharpoons ' refer to the equilibrium reactions and are used to shorten the expression.⁷⁹ They should not be taken to mean that the path would be the same on heating and cooling; rather, any combination of the above paths is possible. Thus, in category a) there are two possible paths on heating and two on cooling.

The parallel transitions of category b) are seen on a DSC curve as separate or overlapping peaks of transitions IV \rightleftharpoons III and IV \rightleftharpoons II.¹ These transitions may partly reflect the inhomogeneity of the samples, especially where the peaks are separate.

The forward-and-back transitions of category c) were seen on heating as complex peaks starting with an endothermic peak at onset temperature of transition IV \rightarrow II and followed by an exothermic peak after the first peak.¹ The exotherm may begin immediately after the endotherm or it may be delayed by several degrees as in Fig. 3.2. These transitions also appeared on cooling.¹ In the literature⁸⁰ this phase transition path has been associated with the formation of a metastable phase III. The mechanism of the transition is discussed in section 3.5 below, with a conclusion drawn that is contradictory to the literature.^{IV,80}

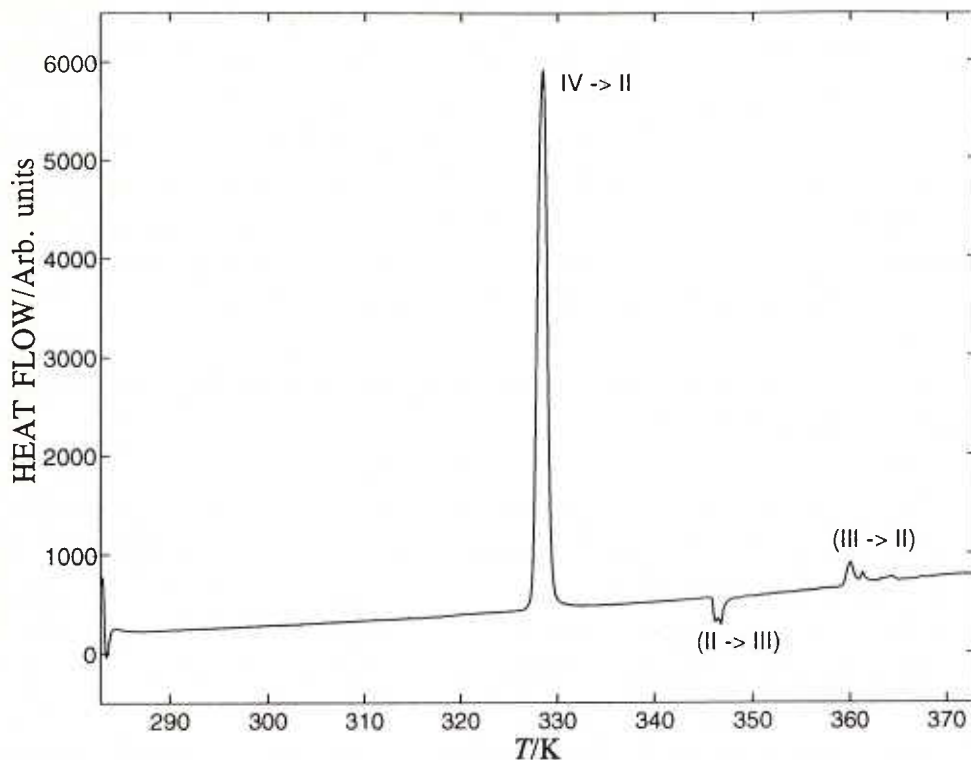

Fig. 3.2. An example of the forward-and-back transition peaks in DSC. An endothermic peak of transition IV \rightarrow II is followed, after several degrees, by an exothermic peak of transition II \rightarrow III.

3.3 Transition temperatures and energies

Figure 3.3 shows some of the transition onset temperatures and energies. The onset temperature of the transition IV \rightarrow III was 314 - 331 K. The transition energy decreased as a function of temperature from 1500 to 1000 J mol⁻¹. The solid line in Fig. 3.3 is the least-squares fit of the values of the IV \rightarrow III transitions. The deviation of the onset temperatures is so great that it cannot be a random error of the temperature determinations but must be a true transition temperature variation.

The onset temperature of the pure transitions IV \rightarrow II was 329 - 331 K and the transition energies 1400 - 1800 J mol⁻¹. Most of the deviation in the transition temperature is of random origin. The mean value of the temperature and transition energy of transition IV \rightarrow II is indicated by a solid circle.

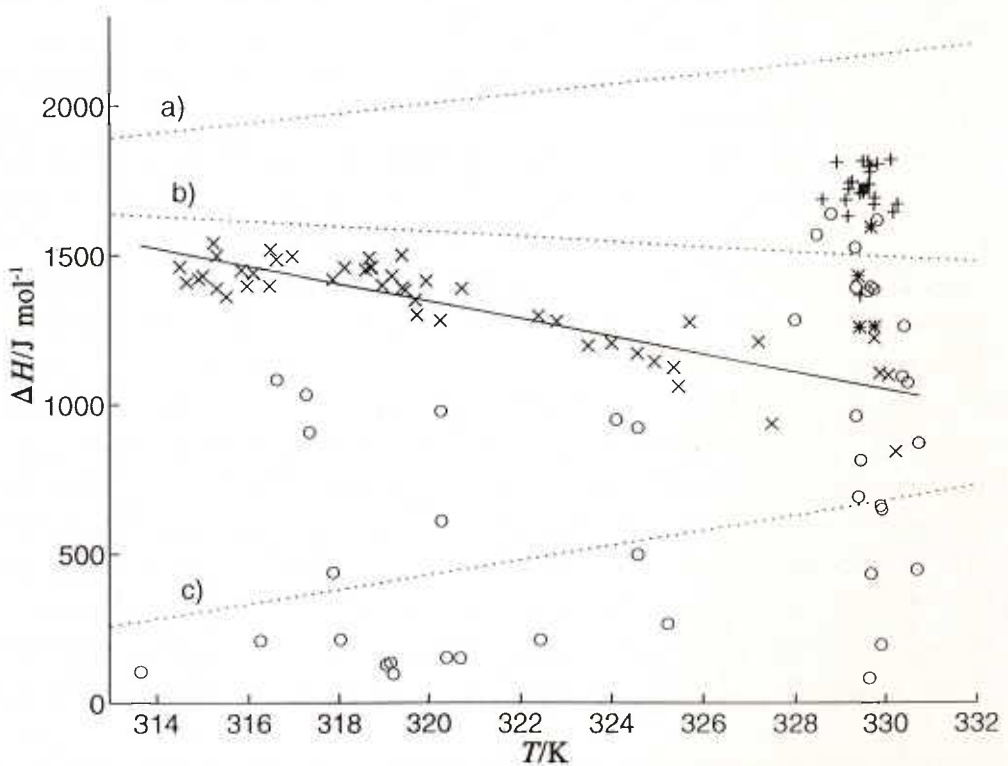

Fig. 3.3. Examples of transition onset temperatures and energies of the transitions starting from ammonium nitrate phase IV. Pure transitions $x = \text{IV} \rightarrow \text{III}$ and $+ = \text{IV} \rightarrow \text{II}$; parallel transitions $o = \text{IV} \rightarrow \text{III}$ or $\text{IV} \rightarrow \text{II}$; forward-and-back transitions $* = \text{IV} \rightarrow \text{II} (\rightarrow \text{III})$. The solid line is the least-squares fit of transitions $\text{IV} \rightarrow \text{III}$ and the solid circle the mean value of transitions $\text{IV} \rightarrow \text{II}$. The dotted lines indicate the difference of the enthalpy between the phases a) IV and III; b) IV and II and c) II and III.⁸¹

The forward-and-back transitions $\text{IV} \rightarrow \text{II} (\rightarrow \text{III})$ at 329 - 330 K had energies 1200 - 1600 J mol⁻¹. In general, the pure $\text{IV} \rightarrow \text{II}$ transitions had higher onset temperature and transition energy than the forward-and-back transitions at maximum.

The parallel transitions $\text{IV} \rightarrow \text{III}$ and $\text{IV} \rightarrow \text{II}$ are scattered over the plot and there are two or more points for each sample. There would be no statistical sense in calculating the mean values for the parallel or the forward-and-back transitions.

The dotted lines in Fig. 3.3 present the values of Nagatani's experiments with an adiabatic calorimeter.⁸¹ Line a) is the enthalpy difference between phases IV and II, line b) that between IV and III and line c) that between phases II and

III. The observed transition energies for transitions $IV \rightarrow III$ and $IV \rightarrow II$ are 10 - 30% smaller than the literature values.⁸¹ The enthalpy difference between phases II and III, line c, is referred to again in section 3.5 where the transition mechanisms are discussed.

Predominant in Fig. 3.3 is that the onset temperatures of the principal transitions, $IV \rightarrow III$ and $IV \rightarrow II$, range widely between 314 and 331 K. The only systematic difference between the samples was the cooling rate of the melt. Since the samples were of the same origin, there could have been no difference in the impurity concentrations. Moreover, the water content was shown not to be related to the transition path.¹

As will be noted in section 3.4 below, the disorder of the crystals evidently varies with the cooling rate of the melt and is responsible for the variation in the onset temperature of the transitions.¹ The wide variation of the onset temperature indicates that instead of distinct phases IV and IV', as proposed in the literature,¹¹ phase IV can exist in different degrees of order. The degree of order determines the transition temperature and thereby the energy. The structure changes between two extremes: at the one end are the disordered structures undergoing transition $IV \rightarrow III$ and at the other end the ordered structures undergoing transition $IV \rightarrow II$.

3.4 Effect of the sample preparation method

There was a clear connection between the transition paths and some of the sample preparation methods.¹ Cooling the samples at different rates from the melt had the clearest effect. Fast cooling of the ammonium nitrate melt caused the phase transitions $IV \rightarrow III$ to predominate, whereas slow cooling favoured the $IV \rightarrow II$ transitions. Between the two extremes were the parallel transitions $IV \rightarrow III$ and $IV \rightarrow II$ and the forward-and-back transitions $IV \rightarrow II (\rightarrow III)$. The effect of the cooling rate, it was concluded, was to create samples with different degrees of disorder.¹ The difference then caused the variation of the transition temperature and the different transition paths.

The water concentration did not affect the phase transition path and any of the paths were likely to occur at any concentration.¹ However, change in the water concentration occurring under certain conditions did affect the transition path.¹ Such an effect was observed when DSC sample pans with and without holes were tested. In the pans with holes, samples that underwent transition $IV \rightarrow II$ on first heating to 373 K and whose water concentration was over 0.5% underwent transitions $IV \rightarrow III \rightarrow II$ on the second heating. The change in

transition path did not occur, however, if sample pans without holes were used.¹ When these experiments were repeated in large scale where it was possible to determine the water concentration after the treatments, it was found that drying the samples at elevated temperature affected the transition paths.¹ When samples that underwent transition IV → II and whose water concentration was over 0.5% were dried at 373 K, the transition path changed to IV → III → II. If the samples were dried at room temperature or were heated under cover and therefore not dried, the transition path was not affected.¹

Systematic ageing tests were carried out at different temperatures.¹ Temperature had no effect, but there was a slight tendency for older samples to follow transition IV → II. Some remarks on the effect of sample age, or annealing, on the kinetics of the phase transitions can be found in the literature, but no explanation has been offered for the mechanism.^{66,68,82} The observations of Tang and Torrie³⁵ and Walton *et al.*⁸³ give a reason to suppose that the age could affect the ordering of samples in phase IV.

3.5 Mechanisms of the phase transitions between ammonium nitrate phases IV, III and II

The phase transitions between solid phases IV, III and II of ammonium nitrate are order-disorder transitions where the dynamical orientational disorder decreases as the temperature decreases.^{4-11,14} Brown and McLaren¹⁴ have proposed a solution-recrystallization mechanism for transitions IV ⇌ III, arguing that there is water in crystals undergoing transitions to phase III and virtually no water in crystals undergoing transitions IV ⇌ II. Supporting evidence for the mechanism was offered from optical microscopy, where an interface between phases IV and III was observed in moist samples.¹⁴

As was explained above, in contrast to reports in the literature,^{14,15} samples undergoing transition IV ⇌ II may, in fact, contain substantial amounts of water.¹ This means that the paths IV ⇌ III and IV ⇌ II cannot be distinguished by the solution-recrystallization mechanism.

Another mechanism, proposed by several groups, is that the transition passes through a solid intermediate phase between phases IV and III.^{29,51,84} This interpretation is based on X-ray diffraction and Raman measurements, which indicate that the interface seen in the optical microscopy studies is an intermediate phase II* between phases IV and III. The Raman spectra suggest that the

structure is close to the structure of phase II and that its life-time is one minute at maximum.²⁹

The existence of the intermediate phase II* was confirmed in the combined DSC-Raman investigations.^{ii,iii,iv} Depending on the onset temperature of the transition life-times up to seven minutes were recorded. Nor was it demonstrated that the life-time could not be even longer; the life-time could be increased simply by reducing the heating rate of the samples. Transition IV \rightarrow III without II* was also observed.^{iv} Since the life-time of the intermediate II* decreased when the onset temperature decreased it was reasonably assumed that the life-time became too short to be seen in the spectra.^{iv}

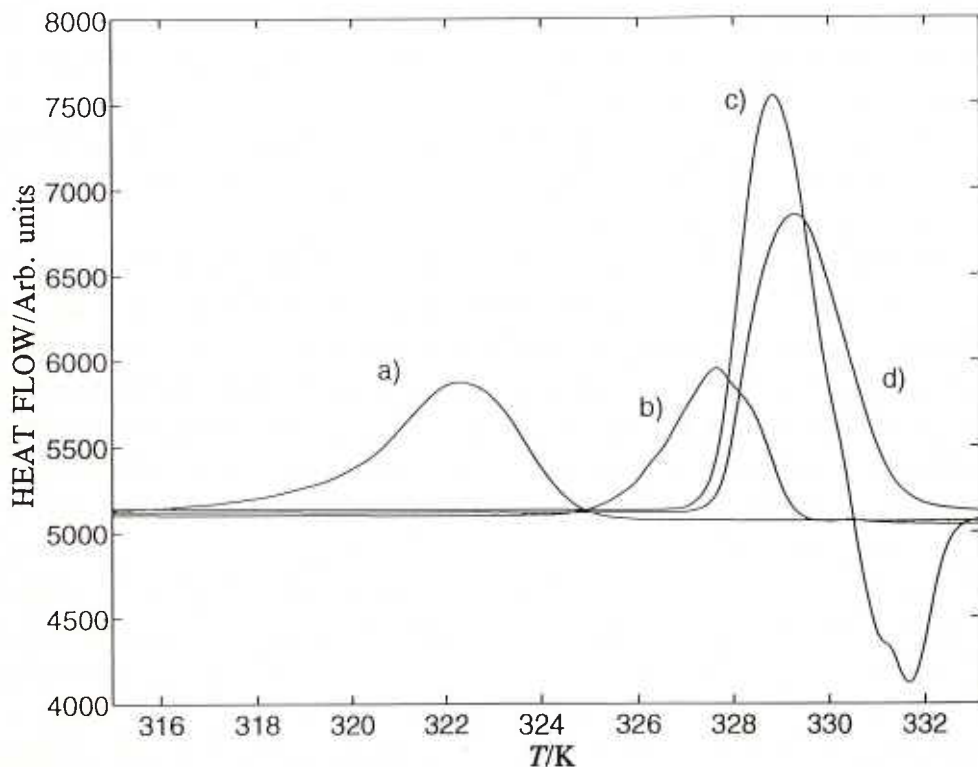

Fig. 3.4. Examples of ammonium nitrate phase transition peaks in DSC. a) and b) of transition IV \rightarrow III at two different temperatures, c) forward-and-back transition IV \rightarrow II (\rightarrow III) and d) pure transition IV \rightarrow II.

The intermediate phase was not seen in the DSC peaks^I of transition IV \rightarrow III. This would suggest that the observed DSC peaks are the product of two opposite peaks overlapping: one for the endothermic transition IV \rightarrow II* and the other for the exothermic transition II* \rightarrow III. In Fig. 3.4, curves a and b represent transition IV \rightarrow III at two different temperatures. Line c is the forward-and-back transition, where the transition II \rightarrow III is seen as an exothermic peak after the transition IV \rightarrow II peak. Line d in Fig. 3.4 is the pure transition IV \rightarrow II.

Figure 3.5 shows the simulated deconvolutions of the peaks b and c in Fig. 3.4. The solid curve represents the total transition as observed. The upper dashed line represents the transitions IV \rightarrow II* and IV \rightarrow II and the lower dashed line the transitions II* \rightarrow III and II \rightarrow III. The peak areas are evaluated from the values presented in Fig. 3.3. The enthalpy values of phases IV, III and II are presented in Fig. 3.6 as reported by Nagatani.⁸¹ When the onset temperature decreases, so do the enthalpy change of transition II* \rightarrow III and the life-time of phase II*. The enthalpy change value becomes zero at about 305 K, which is, interestingly, the equilibrium temperature of phase transition IV \rightleftharpoons III.

There is no sharp distinction between the transitions IV \rightarrow II* \rightarrow III, IV \rightarrow II and IV \rightarrow II (\rightarrow III) in DSC.^{I,IV} This, and the fact that phases II* and II could not be distinguished by their spectra, suggest that the structure of phases II and II* may be the same.^{IV} It can be concluded that the transition between phases IV and III always takes place through the intermediate II*. Transition IV \rightarrow II is an extreme case where phase III does not form by transition II* \rightarrow III because of the strong bonds between nitrate and ammonium ions in the well-ordered crystals.^{IV} The strong bonding enlarges the hysteresis of the overall transition IV \rightarrow III so much that the transition IV \rightarrow II becomes more favoured.

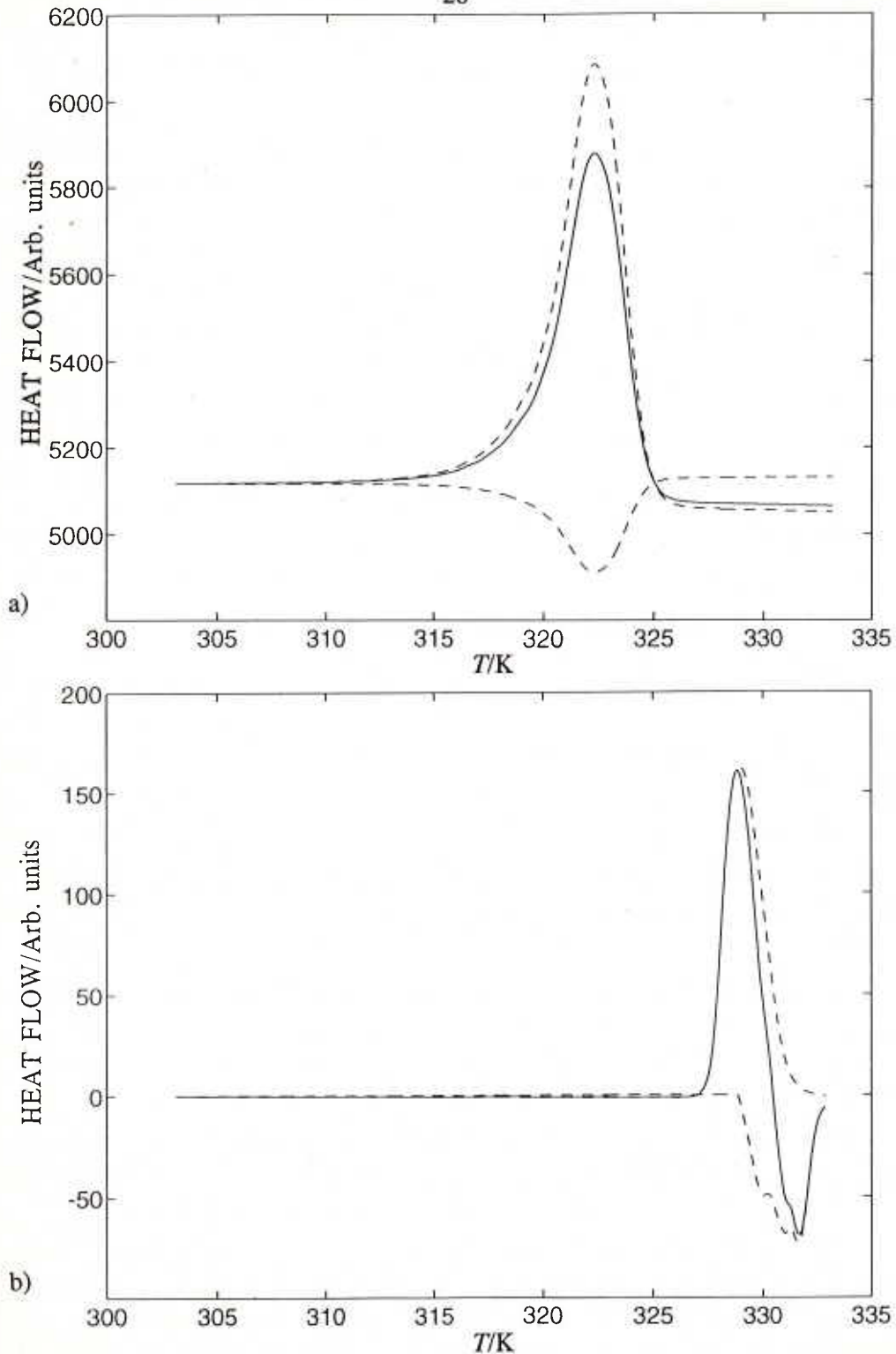

Fig. 3.5. Simulated deconvolutions of ammonium nitrate phase transition peaks: a) transition IV \rightarrow III and b) forward-and-back transition IV \rightarrow II (\rightarrow III). The solid lines indicate the observed transitions. The upper dashed lines are the transitions from IV to II* or II and the lower the transitions from II or II* to III.

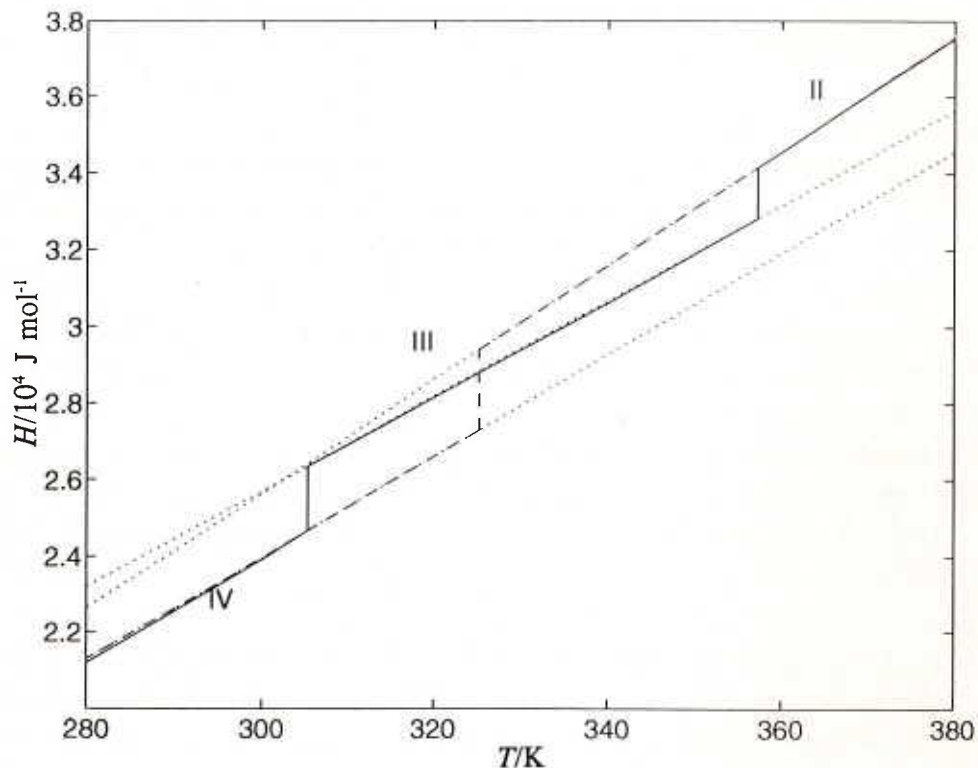

Fig. 3.6. The enthalpy values of ammonium nitrate phases IV, III and II. The figure is plotted from Nagatani's values.⁸¹

3.6 Statistical evaluation of the effect of disorder on the transition paths between ammonium nitrate phases IV, III and II

In the preceding sections it has been argued that the disorder of the ammonium nitrate phase IV crystals^{I-IV} is the dominant factor in the selection between the transition paths IV → III → II and IV → II. The proposal of Hendricks, Posnjak and Kracek¹¹ regarding the phases IV and IV' and some other remarks as to the possible disorder of phase IV, have suggested what the nature of the structural factors affecting the transition path might be, but no relationship between any such factor and the transition paths has been demonstrated.^{35,83,85}

The Raman studies of Tang and Torrie,³⁵ and the NMR studies of Walton *et al.*,⁸³ have suggested that in phase IV the ions may be fixed in two different orientations. Above 292 K, as compared with temperatures below that, the movements of the ammonium ions would be significantly faster and the ions

would move between the two alternative orientations more freely. No attempt was made by either group to find a correlation between the different structures and the transition paths. Since single crystals such as used their work do not easily undergo transitions to phase III, their experiments were not reproduced.

Brooker⁸⁵ reports a broadening or a shoulder of the nitrate symmetric stretching Raman peak at 985 - 1065 cm^{-1} for a variety of nitrates. This could not be explained in terms of the isotopic effect but was attributed to nitrate disorder. For ammonium nitrate, his results indicated disorder in phases I, III, IV and VII. The effect of disorder on the peak shape was significantly smaller in phase IV than in the other phases. Brooker's experiments were repeated to see if the Raman spectra would reveal a correlation between the disorder in phase IV and the transition paths, but no correlation was observed.

Parallel XRD and DSC measurements, with XRD giving information about the structure and DSC about the transition paths, eventually offered a fruitful approach to the study of disorder.^v The XRD curves did not reveal any clear structural differences between the samples. This was as expected from the literature and the presumption that structures would differ only slightly.¹¹ XRD patterns are known to be affected by factors such as sample packing, particle size and orientation of the crystals and these factors were also expected to interfere with the measurements. Partial least-squares regression (PLS) and principal component analysis (PCA) were therefore employed to extract information from highly complex data.^v It was shown that there is, in fact, a relationship between the XRD patterns and the phase transition paths.^v

PLS and PCA are advanced multivariate data analysis methods widely used in chemometrics.^{86,87} PLS has two main uses: to describe the correlation between independent and dependent variables and to predict the unknown dependent variables of samples whose independent variables are known. PLS has already proved itself in quantitative spectroscopy and in quantitative structure-activity relationship (QSAR) calculations.^{87,88} PCA is often used to group samples according to their properties, *i.e.* as a pattern recognition method.^{86,87}

In this investigation the matrix of the independent variables was composed of one XRD curve on each row and one 2θ value in each column.^v The matrix of the dependent variables was a single column matrix containing the transition energies of transition III \rightarrow II of each sample as measured by DSC.^v

PLS score plots with two first components showed distinct clusters according to the phase transition paths IV \rightarrow III and IV \rightarrow II.^v A three-dimensional score plot of three first components showed the clusters even better. This means

that the XRD patterns contained information on the structure factors correlating with the phase transition path.^v

To test the predictive ability of PLS, the transition class and transition energy of a test set were predicted from the XRD patterns.^{v,87} The prediction of the transition class succeeded well and showed that PLS could be used for semiquantitative prediction of the phase transition energy of transition III → II from XRD data.^v

The energy of transition III → II was predicted from the whole XRD 2θ range measured and from smaller 2θ ranges.^v The number of PLS components that was suggested for the model by the cross-validation and the correlation between the observed and predicted energy values varied from one range to the next.^v This may mean that the disorder is more pronounced in some parts of the lattice than in others, but more investigation and development of the data analysis methods is needed before such can be concluded.^v At maximum the correlation was 0.7.

According to the PCA, 7% of the variation in the XRD patterns is of origin related to the phase transition path selection.^v This means that the difference in the XRD patterns is mainly caused by other structural factors than those affecting the phase transition path. This also explains why the visible evaluation of the XRD patterns did not lead to any conclusions.^v

4. CONCLUSIONS

Close study of sample preparation method allowed samples that would undergo specific transitions to be produced in a controlled manner.^I The sample preparation methods influenced the disorder of the sample, and thereby the transition path.^{I,V} When the method created disorder in phase IV crystals, the path on heating was dominantly IV \rightarrow III \rightarrow II. If the crystals were ordered, the path tended to be IV \rightarrow II. The disorder also affected the onset temperature of transition IV \rightarrow III, which ranged anywhere between 314 and 331 K.

The disorder was investigated not only by sample preparation methods but by X-ray powder diffraction studies.^{I,V} The diffraction results were analysed with partial least-squares regression and principal component analysis, and a correlation was found between the diffraction data and the phase transition paths.^V

The PLS and PCA analyses of the phase transitions and crystal data offered a novel approach to the classical problem of the poor reproducibility of ammonium nitrate phase transitions IV \rightarrow III \rightarrow II and IV \rightarrow II. The methods have rarely been applied to the interpretation of XRD data, but they performed well and deserve to be used more widely.^V Better methods of prehandling the data should be developed for the purpose.

The simultaneous Raman and differential scanning calorimeter investigations confirmed the existence of the intermediate phase II* between phases IV and III. The variation in life-time and the Raman spectra of this phase strongly suggested that phases II and II* are identical in structure and are, in fact, the same phase.^{IV}

The simultaneous DSC and Raman measurements proved to be an effective way of obtaining calorimetric and structural information about the ammonium nitrate phase transitions.^{II,III,IV} The method can be recommended for other similar problems where the reactions are difficult to reproduce, for the analysis of samples available in only minute amount and for cases where supplementary information is needed to interpret the results of thermal analysis.

Some areas of the basic research on ammonium nitrate are in need of more attention. Resolution of the crystal structure of phase II* and detailed investigations on the disorder of phase IV have so far been technically impossible,

but the recent developments in X-ray and neutron diffraction techniques for powder samples should allow them.

The impetus for the work described was to understand better the solid state transitions of ammonium nitrate that affect the physical and quality properties of ammonium nitrate fertilizer. The investigations were carried out with pure ammonium nitrate under controlled conditions and focused on the reproducibility of certain of the phase transitions. The results suggest a new approach to fertilizer investigations, and expanding the methods of this investigation to real world samples is strongly recommended.

5. REFERENCES

List of the original publications by the author:

- I. Harju, M. E. E. and Valkonen, J., Effect of sample treatment on the phase transition paths of ammonium nitrate solid state phases IV, III and II, *J. Therm. Anal.* 39 (1993) 681.
- II. Harju, M. E. E., Valkonen, J. and Jayasooriya, U. A., Simultaneous application of Fourier transform Raman spectroscopy and differential scanning calorimetry for the *in situ* investigation of phase transitions in condensed matter, *Spectrochim. Acta, Part A*: 47 (1991) 1395. Erratum, *Spectrochim. Acta, Part A*: 49 (1993) i.
- III. Harju, M. E. E., Valkonen, J., Jayasooriya, U. A., Wolverson, D., Simultaneous application of charge coupled device array-detected Raman spectroscopy and differential scanning calorimetry to *in situ* investigation of phase transitions in condensed matter, *J. Chem. Soc., Faraday Trans.* 88 (1992) 2717.
- IV. Harju, M. E. E., Solid-state transition mechanisms of ammonium nitrate phases IV, III and II investigated by simultaneous Raman spectrometry and differential scanning calorimetry, *Appl. Spectrosc.* 47 (1993) 1926.
- V. Harju, M. E. E., Minkkinen, P. and Valkonen, J., Transition paths between phases IV, III and II of ammonium nitrate predicted from X-ray powder diffractometer and differential scanning calorimeter data by partial least-squares regression, Manuscript, *Chemom. Intell. Lab. Syst.*, in press.

Literature references:

1. Brunborg, I. and Holmesland, P. B. In: Keleti C., Ed., *Nitric Acid Fert. Nitrates*, Marcel Dekker, Inc., New York, 1985, 1.
2. Highnett, T. P., Ed., *Fertilizer Manual*, Martinus Nijhoff / Dr. W. Junk Publishers, Dordrecht, The Netherlands, 1985, 100.
3. Shah, K. D. and Roberts, A. G. In: Keleti C., Ed., *Nitric Acid Fert. Nitrates*, Marcel Dekker, Inc., New York, 1985, 171.
4. Lucas, B. W., Ahtee, M. and Hewat, A. W. *Acta Crystallogr. Sect. B: Struct. Crystallogr. Cryst. Chem. B35* (1979) 1038.
5. Lucas, B. W., Ahtee, M. and Hewat, A. W. *Acta Crystallogr. Sect. B: Struct. Crystallogr. Cryst. Chem. B36* (1980) 2005.
6. Choi, C. S., Mapes, J. E. and Prince, E. *Acta Crystallogr. Sect. B: Struct. Sci B28* (1972) 1357.
7. Ahtee, M., Smolander, K. J., Lucas, B. W. and Hewat, A. W. *Acta Crystallogr. Sect. C: Cryst. Struct. Commun. C39* (1983) 651.
8. Bridgman, P. W. *Proc. Am. Acad. Arts Sci. 51* (1916) 581.
9. Volfkovich, S. I., Rubinchik, S. M. and Kozhin, V. M. *Bull. Acad. Sci. USSR, Div. Chem. Sci., Engl. Transl. 209* (1954) 167.
10. Medina, J., Sherman, W. F. and Wilkinson, G. R. *Proc. Int. Conf. Raman Spectrosc. 8th* (1982) 401.
11. Hendricks, S. B., Posnjak, E. and Kracek, F. C. *J. Am. Chem. Soc. 54* (1932) 2766.
12. Shah, K. D and Roberts, A. G. In: Keleti C., Ed., *Nitric Acid Fert. Nitrates*, Marcel Dekker, Inc., New York, 1985, 261.
13. Sjölin, C. *J. Agric. Food. Chem. 20* (1972) 895.
14. Brown, R. N. and McLaren, A. C. *Proc. R. Soc. London A: 266* (1962) 329.
15. Sjölin, C. *J. Agric. Food Chem. 19* (1971) 83.
16. Davey, R. J., Ruddick, A. J., Guy, P. D., Mitchell, B., Maginn, S. J. and Polywka, L. A. *J. Phys. D: Appl. Phys. 24* (1991) 176.
17. Davey, R. J., Guy, P. D., Mitchell, B., Ruddick, A. J. and Black, S. N. *J. Chem. Soc., Faraday Trans. 1 85* (1989) 1795.
18. Rasulic, G., Milanovic, L. and Jovanovic, S. *J. Therm. Anal. 34* (1988) 1195.
19. Juopperi, O. *Ann. Acad. Sci. Fenn., Ser. A6 384* (1972) 3.

20. Amorós, J. L., Arrese, F. and Canut, M. *Z. Kristallogr.* 117 (1962) 92.
21. Ahtee, M., Smolander, K. J., Lucas, B. W. and Hewat, A. W. *Acta Crystallogr. Sect. B: Struct. Sci.* B39 (1983) 685.
22. Choi, C. S. and Prask, H. J. *Acta Crystallogr. Sect. B: Struct. Sci.* B39 (1983) 414.
23. Fernandez, J. R., Ganguly, S. and Rao, C. N. R. *Spectrochim. Acta, Part B: 35* (1979) 1013.
24. Kearley, G. J., Kettle, S. F. A. and Oxton, I. A. *Spectrochim. Acta, Part A: 36* (1980) 507.
25. Shen, Z., Sherman, W. F., Wilkinson, G. R. *J. Mol. Struct.* 143 (1986) 51.
26. James, D. W., Carrick, T. and Leong, W. H. *Chem. Phys. Lett.* 28 (1974) 117.
27. Abolin'sh, Y. Y., Karpov, S. V. and Shultin, A. A. *Sov. Phys. Solid State Engl. Transl.* 19 (1977) 2067.
28. Tang, H. C. and Torrie, B. H. *J. Phys. Chem. Solids* 39 (1979) 845.
29. Kearley, G. J. and Kettle, S. F. A. *J. Chem. Soc., Faraday Trans. 1* 78 (1982) 3691.
30. Kearley, G. J. and Kettle, S. F. A. *J. Phys. Chem.* 86 (1982) 4007.
31. Kearley, G. J. and Kettle, S. F. A. *J. Mol. Struct.* 79 (1982) 319.
32. Kearley, G. J., Kettle, S. F. A. and Oxton, I. A. *Spectrochim. Acta, Part A: 36* (1980) 419.
33. Kearley, G. J. and Kettle, S. F. A. *J. Chem. Phys.* 73 (1980) 2129.
34. Abolin'sh, Y. Y., Karpov, S. V. and Shultin, A. A. *Phys. Status Solidi B* 115 (1983) K1.
35. Tang, H. C. and Torrie, B. H. *J. Phys. Chem. Solids* 38 (1977) 125.
36. Akiyama, K., Morioka, Y. and Nakagawa, I. *Bull. Chem. Soc. Jpn.* 54 (1981) 1662.
37. Dalterio, R. A. and Owens, F. J. *J. Phys. Chem. Solids* 49 (1988) 1303.
38. Jayasooriya, U. A., Kearley, G. J. and Kettle, S. F. A. *J. Chem Soc., Chem. Commun.* (1980) 745.
39. Kamiyoshi, K. and Yamakami, T. *Sci. Rep. Res. Inst. Tokohu Univ. Ser. A: 11* (1959) 418.
40. Kamel, R., Badr, Y. and Ismail, F. *Egypt. J. Phys.* 9 (1979) 33.

41. Makosz, J. J. *Acta Phys. Pol. A* 42 (1972) 63.
42. Riggin, M. T., Knispel, R. R. and Pintar, M. M. *J. Chem. Phys.* 56 (1972) 2911.
43. Wasylshen, R. E. *Spectrochim. Acta, Part A*: 40 (1984) 115.
44. Selinger, J., Žagar V. and Blinc, R. Z. *Phys. B: Condens. Matter* 77 (1989) 439.
45. Ratcliffe, C. I., Ripmeester, J. A. and Tse, J. S. *Chem. Phys. Lett.* 99 (1983) 177.
46. Marino, R. A. and Bulusu, S. J. *Energ. Mater.* 3 (1985) 57.
47. Gibby, M. G., Griffin, R. G., Pines, A. and Waugh, J. S. *Chem. Phys. Lett.* 17 (1972) 80.
48. Nilakantan, P. *Phys. Rev.* 52 (1937) 383.
49. de Sáenz, I. M., Tessore, J. C. and Leone, R. *Schweiz. Mineral. Petrogr. Mitt.* 50 (1970) 209.
50. Seiyama, T. and Yamazoe, N. *J. Cryst. Growth* 2 (1968) 255.
51. Ingman, J. S., Kearley, G. J. and Kettle, S. F. A. *J. Chem. Soc., Faraday Trans. 1* 78 (1982) 1817.
52. Meerman, P. G. *Recl. Trav. Chim. Pays-Bas* 60 (1941) 363.
53. Ahtee, M., Kurki-Suonio, K., Lucas, B. W. and Hewat, A. W. *Acta Crystallogr. Sect A: Cryst. Phys. Diffr. Theor. Gen. Crystallogr.* A35 (1979) 591.
54. Choi, C. S. and Prask, H. J. *Acta Crystallogr. Sect. B: Struct. Crystallogr. Cryst. Chem.* B38 (1982) 2324.
55. Cady, H. H. *Propellants Explos.* 6 (1981) 49.
56. Shinnaka, Y. *J. Phys. Soc. Jpn.* 14 (1959) 1073.
57. Yamamoto, S. and Shinnaka, Y. *J. Phys. Soc. Jpn.* 37 (1974) 724.
58. Canut-Amorós, M. and Amorós, J. L. *Z. Kristallogr.* 127 (1968) 44.
59. Wong, S. F., Gillan, B. E. and Lucas, B. W. *Acta Crystallogr. Sect. B: Struct. Sci.* B40 (1984) 342.
60. Shinnaka, Y. *J. Phys. Soc. Jpn.* 14 (1959) 1707.
61. Abolin'sh, Y. Y., Karpov, S. V. and Shultin, A. A. *Sov. Phys. Solid State Engl. Transl.* 23 (1981) 672.
62. Kearley, G. J. and Kettle, S. F. A. *J. Crystallogr. Spectrosc. Res.* 12 (1982) 83.

63. Watson, S., O'Naill, M. J., Justin, J. and Brenner, N. *Anal. Chem.* 36 (1964) 1233.
64. Ungar, G. and Feijoo, J. L. *Mol. Cryst. Liq. Cryst.* 180B (1990) 281.
65. Mirabella, F. M., Jr. *Appl. Spectrosc.* 40 (1986) 417.
66. Kestilä, E., Harju, M. E. E. and Valkonen, J. *Thermochim. Acta* 214 (1993) 67.
67. Shinnaka, Y. and Yamamoto, S. *J. Phys. Soc. Jpn.* 57 (1988) 2739.
68. Shinnaka, Y. *J. Phys. Soc. Jpn.* 11 (1956) 393.
69. Kestilä, E. and Valkonen, J. *Thermochim. Acta* 214 (1993) 305.
70. *JCPDS-ICDD, Cards 9-74, 9-132, 8-499, 8-452 and 11-36*, received from the Powder Diffraction File, PDF-2 Database, Set 1-41, CD ROM Version, JCPDS-International Center for Powder Diffraction Data, Swarthmore, USA 1991.
71. Sramko, T. and Jona, E. *Thermochim. Acta* 92 (1985) 731.
72. Juopperi, O. A. *Thermochim. Acta* 9 (1974) 353.
73. Dellien, I. *Thermochim. Acta* 55 (1982) 181.
74. Rasulic, G., Jovanovic, S. and Milanovic, L. *J. Therm. Anal.* 30 (1985) 65.
75. Breuer, K.-H. and Eysel, W. *Thermochim. Acta* 57 (1982) 317.
76. Sowell, R. R., Karnowsky, M. M. and Walters, L. C. *J. Therm. Anal.* 3 (1971) 119.
77. Filipescu, L., Fatu, D., Coseac, T., Mocioi, M. and Segal, E. *Thermochim. Acta* 97 (1986) 229.
78. Jona, E., Sramko, T. and Nagy, D. *J. Therm. Anal.* 27 (1983) 37.
79. Erofeev, B. V. and Mitskevich, N. I. *Zh. Fiz. Khim.* 24 (1950) 1235.
80. Langfelderova, H. and Ambrovic, P. *Thermochim. Acta* 56 (1982) 385.
81. Nagatani, M., Seiyama, T., Sakiyama, M., Suga, H. and Seki, S. *Bull. Chem. Soc. Jpn.* 40 (1967) 1833.
82. Yamazoe, N., Miohara, M., Seiyama, T. *Kogyo Kagaku Zasshi* 71 (1968) 1813.
83. Walton, A., Sharp, A. R., Petch, H. E. and Pintar, M. M. *Phys. Rev. B: Condens. Matter.* 5 (1972) 4281.
84. Engel, W. and Charbit, P. *J. Therm. Anal.* 13 (1978) 275.
85. Brooker, M. H. *J. Chem. Phys.* 68 (1978) 67.

86. Wold, S., Esbensen K. and Geladi, P. *Chemom. Intell. Lab. Syst.* 2 (1987) 37.
87. Geladi, P. and Kowalski, R. *Anal. Chim. Acta* 185 (1986) 1.
88. Wold, S., Albano, C., Dunn W. J., III, Edlund, U., Esbensen, W., Geladi, P., Hellberg, S., Johansson, E., Lindberg, W. and Sjöström, M. *NATO ASI Ser., Ser. C* 138 (1984) 17.
89. Wold, S. *Technometry* 20 (1978) 397.